

SubC Partner A/S

JibFlex®

JF-200-3

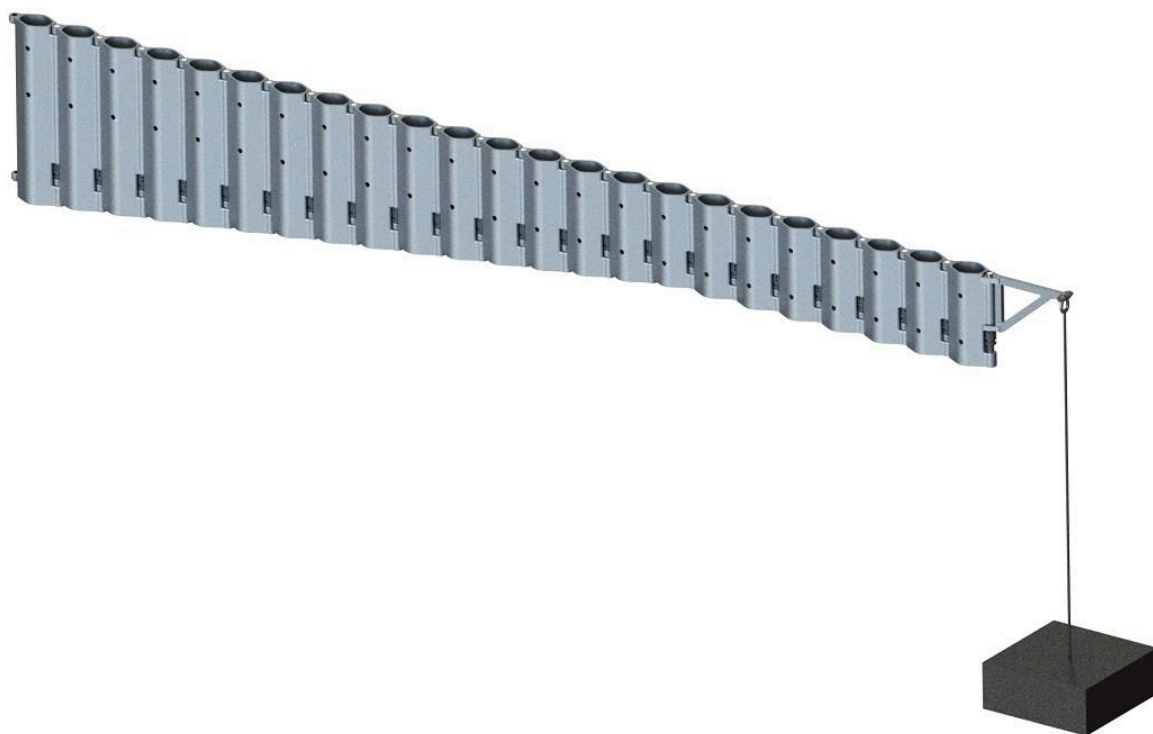

Version 2
02-01-2017

Contents

- 1. Legal.....2
 - 1.1 EC declaration of conformity2
 - 1.2 Safety and Compliance3
- 2. Description of JibFlex JF 200-3:4
 - 2.1 Description of JibFlex Module5
 - 2.2 Description of Stork6
 - 2.3 Attachment of JibFlex7
- 3. Lifting procedure8
 - 3.1 Installation8
 - 3.1.1 Assembly of JibFlex system.....8
 - 3.1.2 Installation of stork..... 10
 - 3.1.3 Flexhose installation 12
 - 3.2 Initiation..... 13
 - 3.3 During Use of JibFlex..... 13
 - 3.4 Disassembly 13
- 4. Training..... 14
- 5. Maintenance..... 15
 - 5.1 Daily inspections, ongoing maintenance 15
 - 5.2 Annual Inspection 15
 - 5.2.1 Visual inspection..... 15
 - 5.2.2 Inspection of functionality..... 15
 - 5.2.3 Load test 16
 - 5.2.4 Reporting 16
 - 5.2.5 Supplemental information 16
 - 5.3 Ten year inspection..... 16
- 6. Part List..... 17
 - 6.1 Main Parts..... 17
 - 6.2 Spare Parts 17

1.1 EC declaration of conformity



EC declaration of conformity

We: **SubC Partner**
 Of: **Sahara 4**
DK, 6700 Esbjerg

In accordance with the following Directives:
 Order No. 612 of 25 June 2008 on the Design of Technical Equipment (Denmark)

&
 2006/42/EC Machine directive

Hereby declares that:

Machine name: **JibFlex JF 200-3**
 Machine number: **Generic User Manual**

Is in conformity with the applicable requirements of the following documents:

Ref. No.	Title	Edition/date
AT Nr. 612	Order No. 612 of 25 June 2008 on the Design of Technical Equipment	2008
2006/42/EC	Machine directive	2006
DS/EN ISO 13849-1	Safety of machinery - Part 1: General principles for design	2006
DS/EN ISO 12100	Safety of machinery - General principles for design - Risk assessment and risk reduction	2011
LOLER L113	Lifting Operations and Lifting Equipment Regulations	1998



Signed by: _____









Name: Rune Vaerndal

Position: COO, JibFlex
 Done at: SubC Partner
 On: 03/03/2020

The technical documentation for the machinery is available from:
 Name: SubC Partner, Esbjerg
 Address: Sahara 4, 6700 Esbjerg, DK

1.2 Safety and Compliance

Any lifting operation performed with JibFlex must be planned to take the following general warnings into account.

Warnings	
	Read the safety and operation instructions before usage of JibFlex.
	Do not operate the JibFlex with wind speeds exceeding 15 m/s
	Do not exceed the predefined SWL/WLL of the JibFlex, which includes the load and lifting equipment.
	Plan the lifting operations such that no individuals or objects obstruct the JibFlex.
	Plan the lifting operations such that no individuals are located under a suspended load. The JibFlex is a suspended load.
	The JibFlex must be installed on lifting points designed specifically for this.
	Lifting operations using the JibFlex must be performed by a competent operator.
	Lift of personnel with the JibFlex is NOT allowed.

The JibFlex can be operated safely by two individuals, which allows one person to be dedicated to controlling the movements of the JibFlex.

2. Description of JibFlex JF 200-3:

JibFlex is a module based lifting device (jib arm) designed to support lifting operations. The structural characteristics of JibFlex JF 200-3 is defined in the table below.

Table 1: Mechanical properties of JF 200-3 (Lifting capacity, lifting radius, module height and module weight)

Module No.	1	2	3	4	5	6	7	8	9	10	11	12	13
Lifting Radius [m]	0.585	0.790	0.995	1.200	1.405	1.610	1.815	2.020	2.225	2.430	2.635	2.840	3.045
WLL [kg]	500	500	500	500	500	460	395	345	305	270	245	220	200
Profile Height [m]	0.475	0.450	0.425	0.400	0.400	0.400	0.400	0.400	0.400	0.400	0.400	0.400	0.400
Profile Mass [kg]	8.6	8.1	7.7	7.3	7.3	7.3	7.3	7.3	7.3	7.3	7.3	7.3	7.3
Deflection from WLL [m]	< 0.02	< 0.02	< 0.02	0.02	0.02	0.03	0.03	0.03	0.03	0.04	0.04	0.04	0.04

The JibFlex modules are delivered with a lifting arm (Stork) that can be mounted on each module. The stork must be mounted with two Ø20 Lockpins delivered with the JF system. The load may only be fixated in the lifting-eye of the stork (Diameter 17 mm). A Ø16 shackle is recommended.

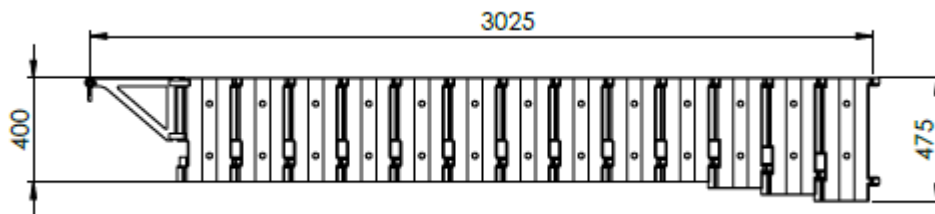

The stork must be mounted with both lockpins and secured with linchpins before execution of lifting operations. JibFlex can be used for lifting from a fixed surface/platform to another fixed surface/platform. JibFlex JF 200-3 may not be used for lifting operations performed on unstable foundation.

The lifting operation of a JibFlex must be planned such that no operators will be located below the assembled JibFlex. Two operators must be present when lifting in order to prevent inadvertent movement of the JibFlex.

2.1 Description of JibFlex Module

The following section is a general description of a JibFlex module:

JibFlex Module

1. Bushing without flange
DWG: PB-002
2. Bushing with flange
DWG: PB-001
3. Holes for Lockpins $\varnothing 20$
4. Taps for module-mounting
DWG: TA-001
5. Machined JF Module
DWG: M-XXX

Complete Module
DWG: M-XXX-1

The modules are designed such that a rotation of 62° can occur between one module and the previous. This yields a turning diameter of approximately 500 mm as illustrated below:

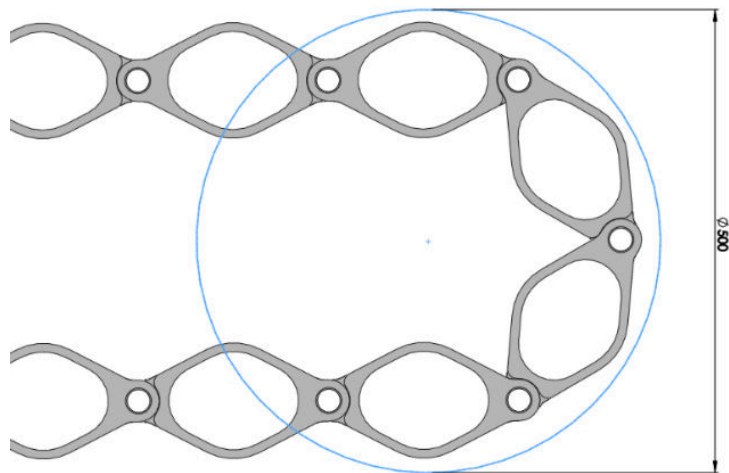

2.2 Description of Stork

The lifting arm/lifting eye for attachment of lifting equipment is called a Stork. The following section is a general review of the stork.

For procedures regarding use of stork see chapter 3.1.2.

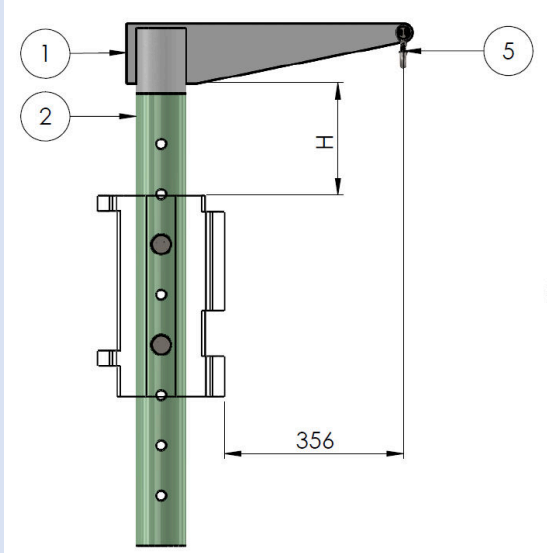
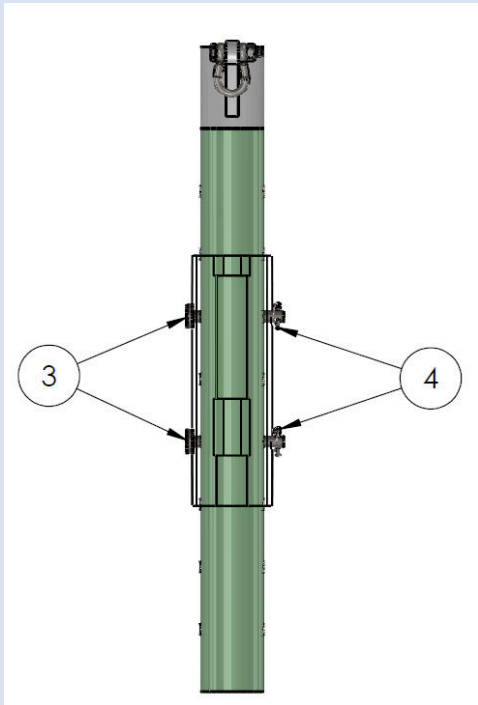
Stork	
	<ol style="list-style-type: none"> 1. Aluminium body of Stork: DWG: S-00X 2. Polymer Lining: DWG: S-011 3. Lockpins $\varnothing 20$: DWG: S-012 4. Linchpin: DWG: S-014 5. Shackle $\varnothing 16$: DWG: S-013 <p style="margin-top: 20px;">Complete Stork DWG: S-00X-1</p> <p>Notice: The Stork can be delivered in varying lengths, defined by the number of holes. The standard size is six holes; however, the one depicted has a length of eight holes.</p>
	

2.3 Attachment of JibFlex

The JibFlex must be attached on verified lifting points. The strength requirements of the lifting points for JibFlex JF 200-3 are defined by:

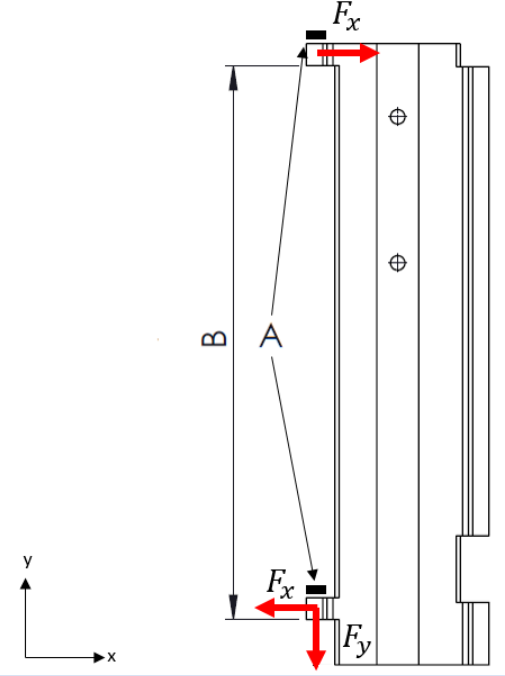
Requirements of Attaching Points	
	<p>A locking mechanism must be implemented at the hinges, marked A, to secure the module from vertical displacement.</p> <p>The distance B and the respective loads are found below.</p> $F_{x,max} = 27 \text{ kN}$ $F_{y,max} = 3.7 \text{ kN}$ $B = 383 \text{ mm}$ <p>The noted reactions are characteristic loads that includes a dynamic amplification factor (DAF), but without partial coefficients/safety factors.</p>

3. Lifting procedure

3.1 Installation

It must be verified that the WLL of the JibFlex is not exceeded before the jib arm is installed.

The JibFlex must be installed on approved lifting points.

The first module of the JibFlex must be secured from vertical displacements due to the snatch loads. The rest of the modules are secured from this effect by the LockBrackets.

3.1.1 Assembly of JibFlex system

The following illustrations describes the assembly of two JibFlex modules in five steps.

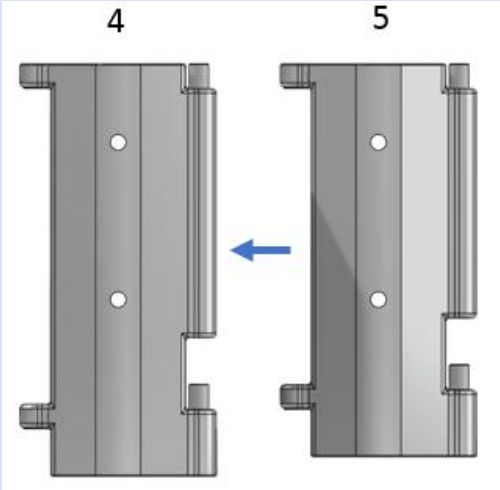
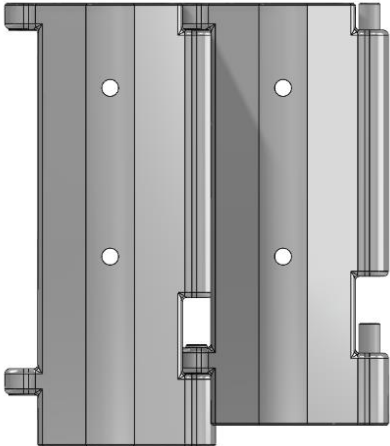
Assembly of JibFlex system	
	<p>Step 1: The modules must be assembled in numerical order as show on the illustration.</p> <p>The two hinges of the fifth module is fitted onto the two taps of the fourth module.</p>
	<p>Step 2: The modules will fit closely and must be able to rotate freely. They are assembled correctly if the planes on the top of the modules are coincident.</p>

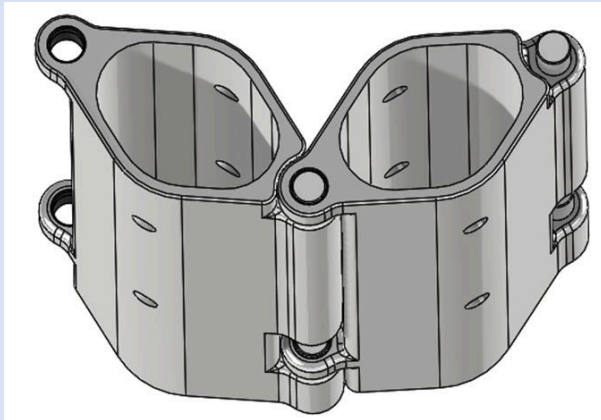

Step 3:

Rotate the modules as shown to ensure the LockBracket can be inserted.

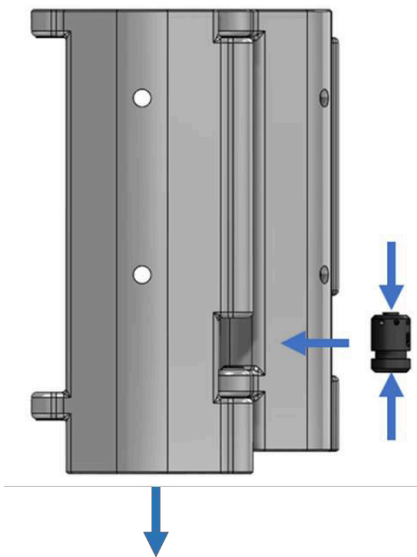

Step 4:

The LockBracket is compressed and placed in the area between the modules such that it rests on the hinge of the fifth module.

Pull the wire inside the module to ensure that the LockBracket is placed correctly.

A distinctive clicking sound verifies that the lock bracket is correctly installed.

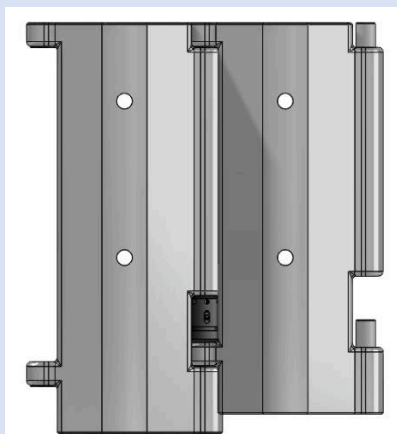

Step 5:

The illustration shows a correctly installed module. The next module can now be installed by repeating the steps.

3.1.2 Installation of stork

Only one stork is allowed to be installed on a JibFlex at any given time. The stork must **always** be installed on the last module of the current JibFlex configuration.

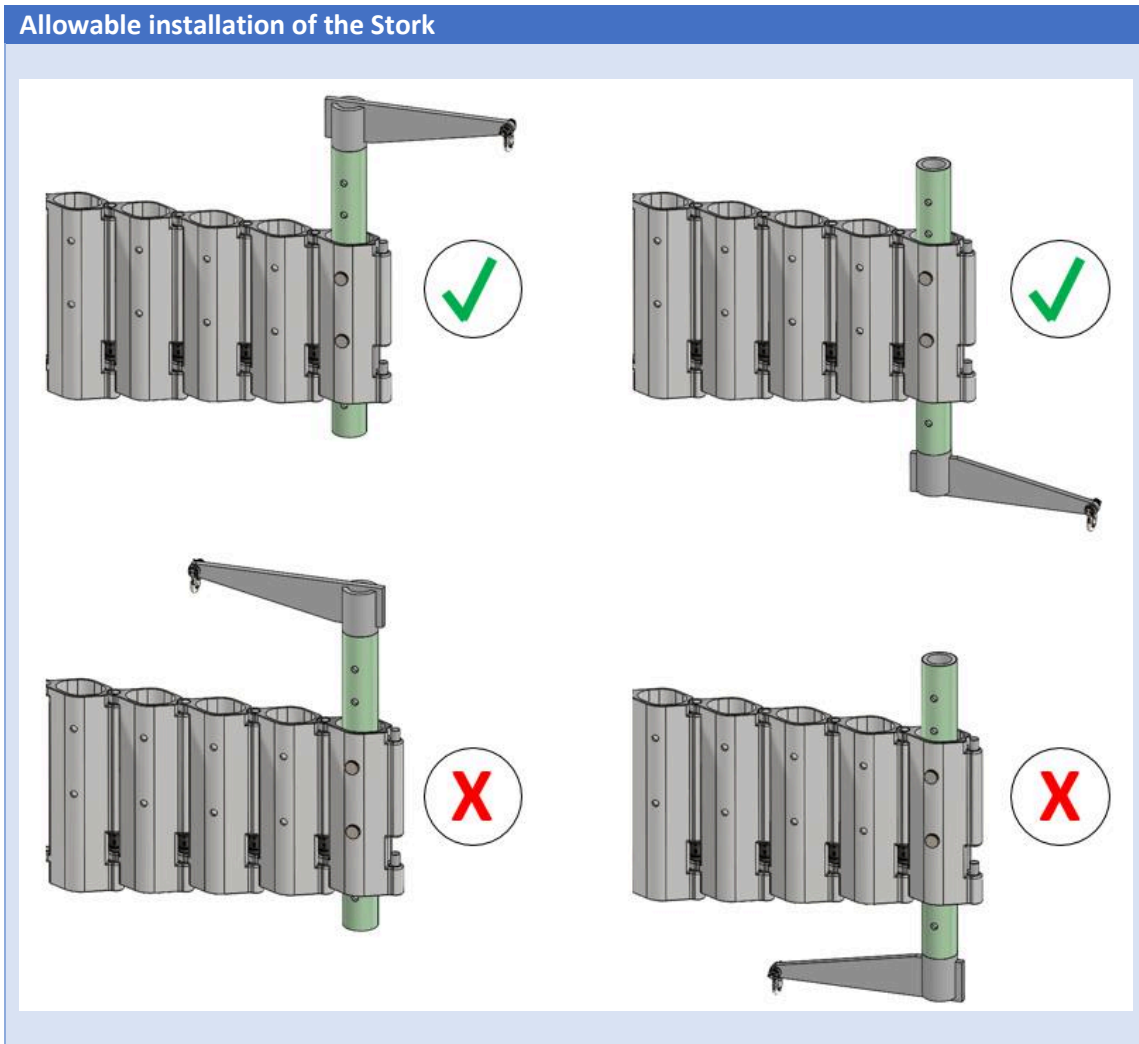

The Stork must be placed in the last module as shown above. The procedure for a general stork is shown on the following illustrations.

Installation of Stork

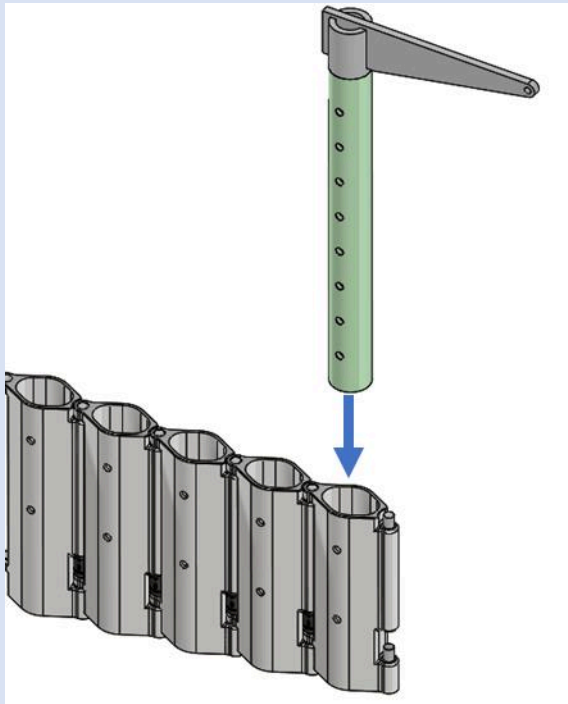

Step 1:

The stork is placed in the last module of the JibFlex such that the required lifting height is achieved.

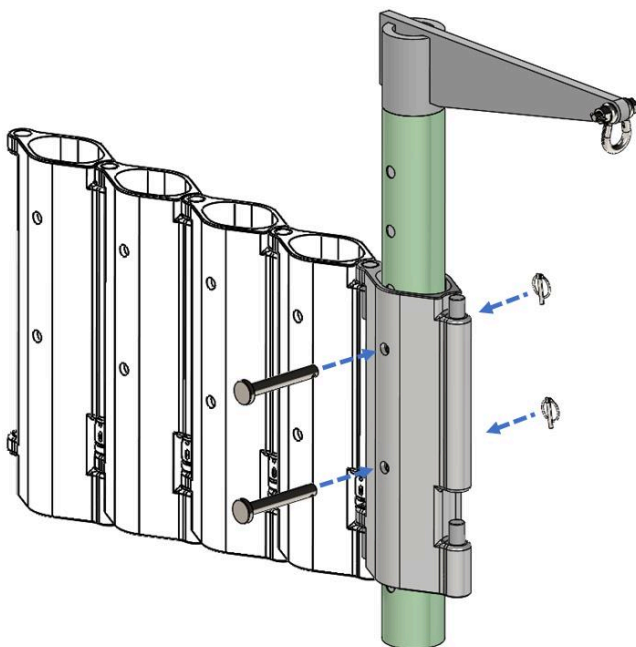

Step 2:

The stork is placed such that the holes on the module and the Stork are coincident. This allows the two Lockpins to be inserted. Two linchpins secure the Lockpins from unwanted displacements. A Ø16 shackle is attached to the lifting eye of the Stork.

3.1.3 Flexhose installation

Both manual and electric hoists can be attached to the Stork. It may be advantageous to run the electric cable through the Flexhose when using an electric hoist. The following section describes the installation of the Flexhose.

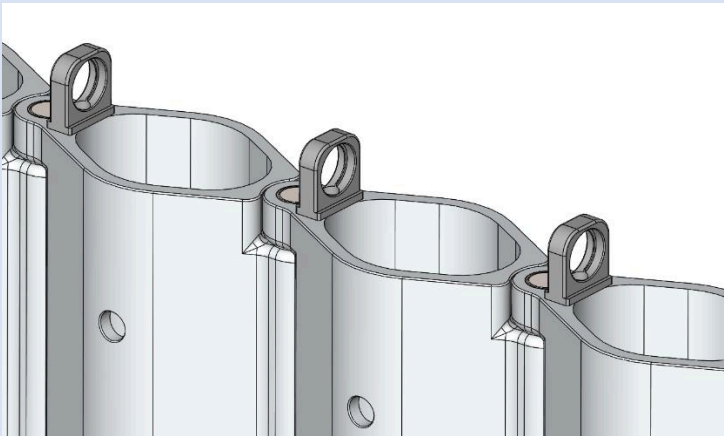
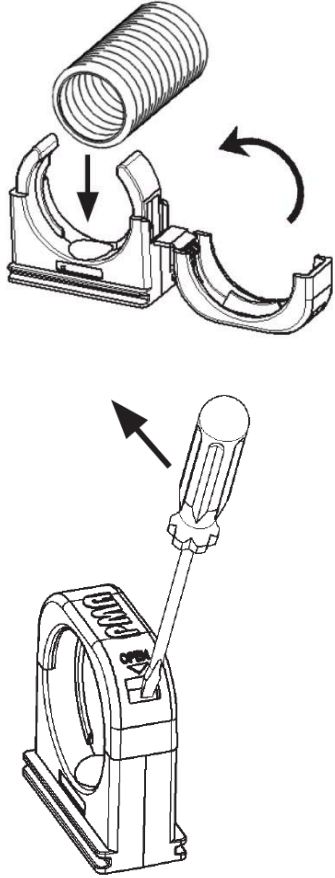
Installation of Flexhose	
	<p>Step 1: Install the enclosed Flexhose Clips on top of each module.</p>
	<p>Step 2: The Flexhose Clips can be opened by inserting a screwdriver into the hole on the side of the clip, and applying a force as shown below. This can also be done by performing the same motion without the screwdriver.</p> <p>Once opened, the Flexhose can be inserted and the clips can be closed, making a distinct 'clicking' sound.</p>

3.2 Initiation

A competent person must inspect the entire assembly of the JibFlex before any lifting operations can be executed.

3.3 During Use of JibFlex

It is essential that JibFlex is secured from unwanted movements and that it is under physical control during operation.

3.4 Disassembly

Disassemble the JibFlex by following the procedure below:

1. De-attach the lifting equipment from the Stork.
2. Remove the two $\varnothing 20$ Lockpins and the Stork.
3. Disassemble the modules by following the steps from Chapter 3.1.1 in reverse. The simplest method is to remove one LockBracket followed by one module and repeating until all modules are separated. See the following illustrations.
4. Remove the snatch-load safety mechanism from the first module and de-attach the first module.

Removal of LockBracket

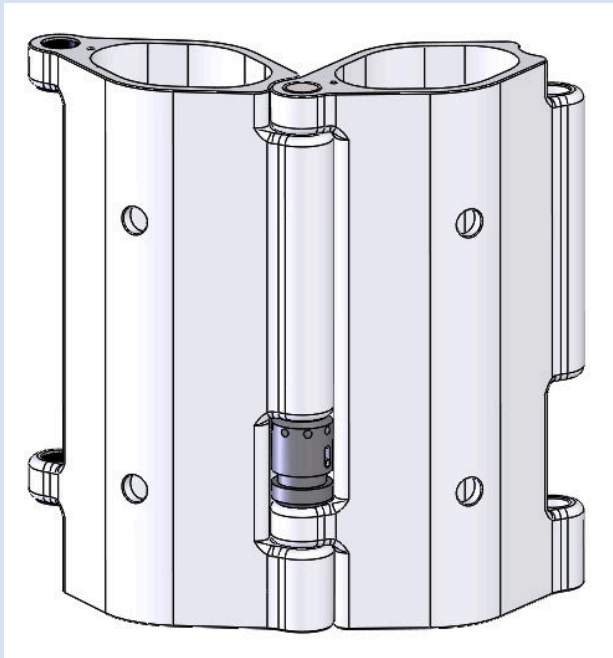

Step 1:

The modules are rotated as shown to expose the LockBracket.

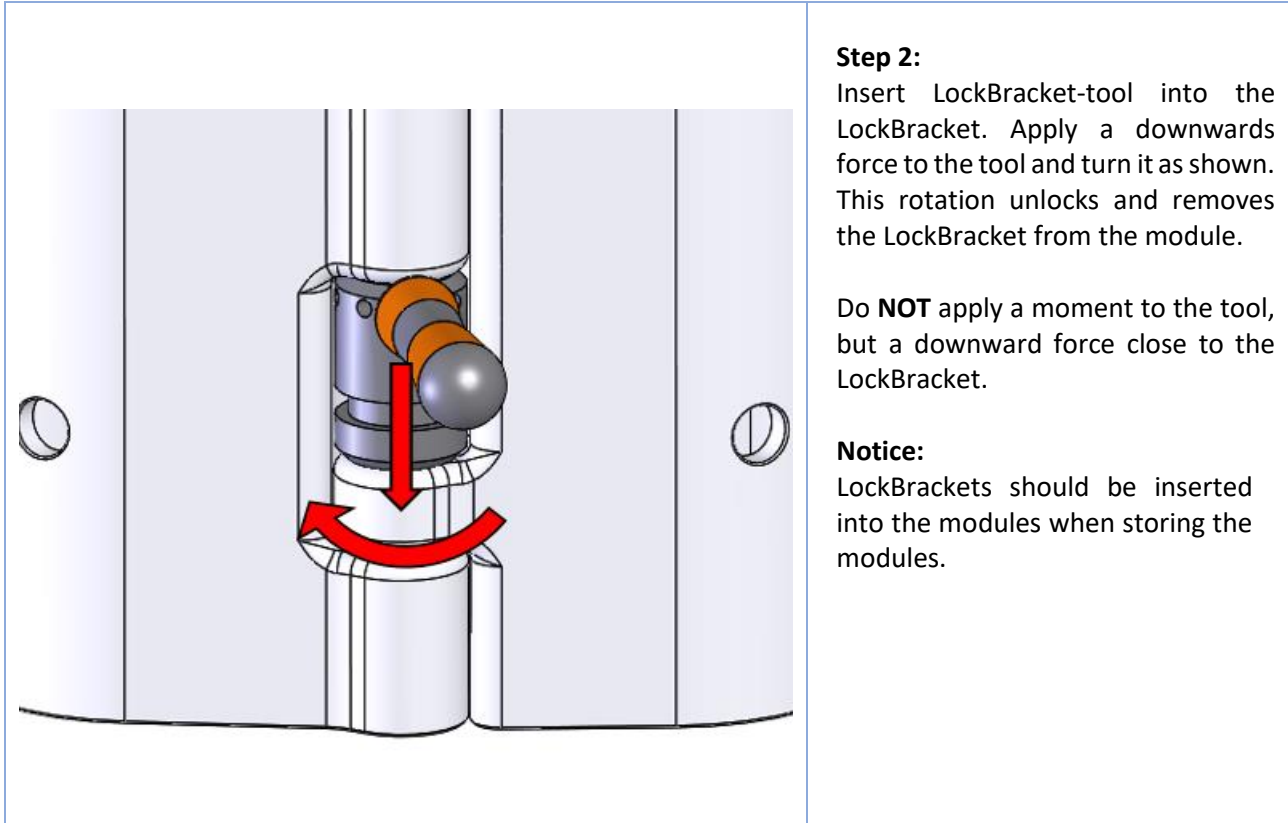

4. Training

The operator of JibFlex must have a basic knowledge qualifying the person to perform lifting operations. Furthermore, the operator must be educated in the assembly, use and disassembly of the JibFlex.

A competent person must have the same training as an operator, but must be competent to evaluate if the chosen JibFlex configuration is assembled correctly and is adequate for the lifting operation. The competent person must be qualified to evaluate the lifting points and choice of additional lifting equipment with respect to the current lifting operation.

5. Maintenance

Maintenance of the JibFlex is performed with respect to daily inspections, ongoing maintenance, annual inspection and inspection every ten years.

5.1 Daily inspections, ongoing maintenance

The JibFlex must be visually inspected for the following when assembling or disassembling the system:

- Damage of JibFlex Modules
- Damage of Polymer Bushings
- Damage of LockBrackets

Clean the JibFlex with freshwater when needed. Store any JibFlex parts in dry locations.

Inspect the lifting points daily when using a JibFlex consistently for several days.

5.2 Annual Inspection

JibFlex is a lifting device (jib arm) which lifts/moves free-hanging loads. The annual inspection of said device must be performed:

At least every 12th month or according to local specific laws and/or requirements.

On used JibFlex before new owner performs lifting operations or according to local specific laws and/or requirements.

After longer periods of idleness of the JibFlex.

The supplier or equally competent service provider with knowledge of the tools must perform the annual inspection. It must satisfy the legal framework and the suppliers' recommendations. The inspection is defined as completion of the three following steps:

5.2.1 Visual inspection

All components of the JibFlex must be inspected visually. All parts must be examined individually and any damaged parts must be replaced. A competent person must focus upon identifying permanent deformation and indications of initiating damage. The lifting eye is a critical component regarding permanent deformation since this can occur if the device is used incorrectly.

5.2.2 Inspection of functionality

The JibFlex is mounted on lifting points and it is controlled that:

- a) LockBracket functions correctly and the wire keeping it in place is intact.
- b) Bushings provide the desired rotation between the JibFlex modules.
- c) Stork and bolts for securing can be installed without difficulties.

5.2.3 Load test

The load test is performed according to the following guidelines:

- a) The JibFlex must be load tested with the load applied in the maximum lifting radius while the JibFlex is mounted on approved lifting points
- b) The load factor to be applied to the load is defined as 150% WLL
- c) The load must be maintained ten minutes for each load JF test

5.2.4 Reporting

There should be given attention to equipment that requires a journal along with the reporting of the annual inspection. This includes lifting equipment used on varying locations.

5.2.5 Supplemental information

The need for certifications should be evaluated at the annual inspection. The location of the operation with JibFlex could require additional certifications, for example LOLER.

Only the supplier of JibFlex can perform any repair should the annual inspection require it. Stork and modules can be replaced by a competent person. Replacement of bushings, LockBrackets is assumed a part of the daily maintenance.

A competent person with regards to annual maintenance of JibFlex is defined as a person who has:

- a) Knowledge of the technical aspects of the JibFlex.
- b) The necessary education and training in service and maintenance of JibFlex.
- c) Knowledge of the user manual.
- d) Knowledge of the requirements specified by the local working environment authority, especially regarding reporting, load test and journal.
- e) Knowledge of requirements from other authorities based on where the JibFlex is used.

5.3 Ten-year inspection

The ten-year inspection replaces the annual inspection and must be performed by a competent person or supplier of JibFlex.

All JibFlex parts must be inspected visually and a new load test must be performed. Additionally, the first module must be inspected using liquid penetrant method to check for development of cracks.

6. Part List

A complete JibFlex consists of the following:

6.1 Main Parts

Part Number	ID	Description	Quantity
1	M-475-1	Module 1	1
2	M-450-1	Module 2	1
3	M-425-1	Module 3	1
4	M-400-1	Module 4-13	10
5	S-006-1	Stork, six holes*	1
6	AP-001	Anchoring point	2

Replacements of any main parts requires new load test.

6.2 Spare Parts

Part Number	ID	Description	Quantity
6	S-012	Ø20 Lockpins	2
7	S-011	Polymer lining	1
8	S-013	Ø16 Shackle	1
9	S-014	Linchpin	2
10	PB-001	Bushings with flange	26
11	PB-002	Bushings without flange	26
12	LB-001-1	LockBrackets Ø44 67,5	13
13	LB-007	LockBracket tool	1
14	WH-001	Flexhose	1
15	WH-002	M6 bolt	13
16	WH-003	M6 washer	13
17	WH-004	Flexhose Clip	13
18	ST-001	Label-pack	1

Spare parts can be replaced during daily maintenance.

* The standard stork has six holes. Contact JibFlex for other sizes and associated documentation.