

Datasheet for JibFlex: JF 100-2

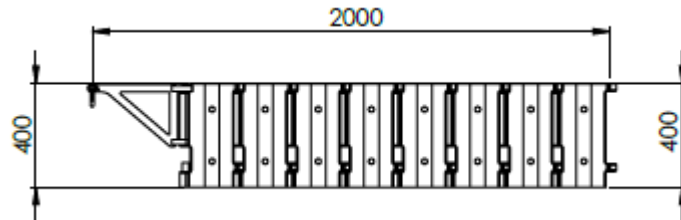

Figure 1: Basic dimensions of JF 100-2.

The lifting eye, called the stork, can be mounted in any module allowing optimisation of every lift. The Stork must always be mounted on the outer module.

The WLL and radius can be seen in the table below:

Module No.	1	2	3	4	5	6	7	8
Lifting Radius [m]	0.585	0.790	0.995	1.200	1.405	1.610	1.815	2.020
WLL [kg]	500	385	280	215	175	140	120	100
Profile Height [m]	0.400	0.400	0.400	0.400	0.400	0.400	0.400	0.400
Profile Mass [kg]	7.3	7.3	7.3	7.3	7.3	7.3	7.3	7.3
Deflection from WLL [m]	< 0.02	< 0.02	< 0.02	< 0.02	< 0.02	< 0.02	< 0.02	< 0.02

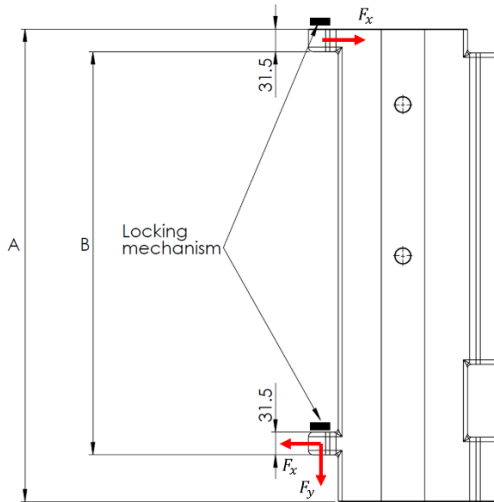

Figure 2: Following structural requirements applies to the supporting structure. The reactions are omnidirectional and characteristic loads that includes dynamic amplification factor (DAF) but without partial coefficients / safety factor.

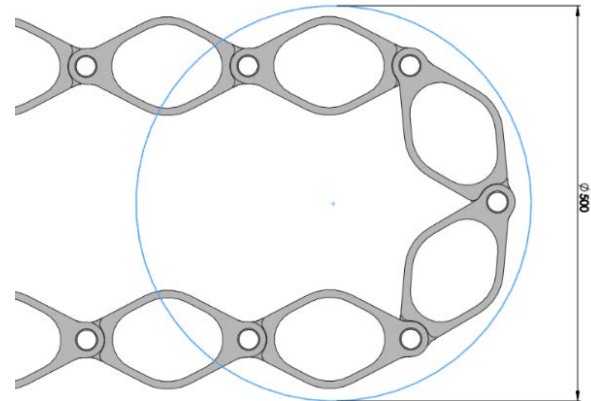

Figure 3: The JibFlex has a bending radius of 250 mm.

Specifications		
Weight of JibFlex		
• JibFlex modules	kg	57
• Stork	kg	12
• Total	kg	69
WLL at last module	kg	285
Max radius	m	2
Maximum deflection cause by WLL	m	<0.02
Safety factor including DAF	-	1.95
Maximum hoist speed	m/s	Unlimited
Installation requirements		
• A	m	0.400
• B	m	0.308
• Fx	N	11000
• Fy	N	7000
Bending Radius	m	0.25

Part List

A complete JibFlex consists of the following:

Main Parts

Part Number	ID	Description	Quantity
1	M-400-1	Module 1-8	8
2	S-006	Stork, six holes*	1

Replacements of any main parts requires new load test.

* The standard stork has six holes.

Spare Parts

Part Number	ID	Description	Quantity
3	S-015	Ø19 Lockpins	2
4	S-013	Ø16 Shackle	1
5	S-014	Linchpin	6
6	PB-001	Bushings with flange	16
7	LB-001-1	LockBrackets Ø44 67,5	8
8	LB-008-1	LockBracket tool	1

Spare parts can be replaced during daily maintenance.

Spare Parts, optional

Part Number	ID	Description	Quantity
	S-008	Stork, eight holes	1
	S-003	Delta Stork	1
	WH-001	Flexhose	1
	WH-002	M6 bolt	8
	WH-003	M6 washer	8
	WH-004	Flexhose Clip	8
	AP-001-1	Standard bracket	2