

Datasheet for JibFlex: JF 200-5

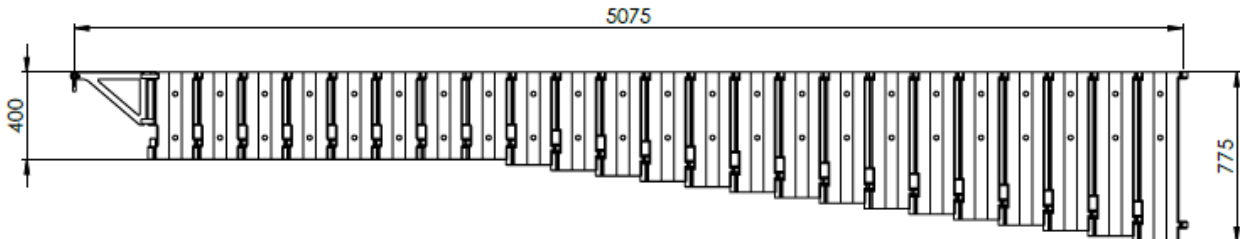

Figure 1: Basic dimensions of JF 200-5.

The lifting eye, called the stork, can be mounted in any module allowing optimisation of every lift. The Stork must always be mounted on the outer module.

The WLL and radius can be seen in the tables below:

Module No.	1	2	3	4	5	6	7	8	9	10	11	12	13	14
Lifting Radius [m]	0.585	0.790	0.995	1.200	1.405	1.610	1.815	2.020	2.225	2.430	2.635	2.840	3.045	3.250
WLL [kg]	500	500	500	500	500	500	500	500	500	500	500	460	420	390
Profile Height [m]	0.775	0.750	0.725	0.700	0.675	0.650	0.625	0.600	0.575	0.550	0.525	0.500	0.475	0.450
Profile Mass [kg]	13.6	13.2	12.8	12.3	11.9	11.5	11.1	10.7	10.2	9.8	9.4	9.0	8.6	8.1
Deflection from WLL [m]	< 0.02	< 0.02	< 0.02	< 0.02	0.02	0.02	0.03	0.03	0.04	0.04	0.04	0.05	0.05	0.06

Module No.	15	16	17	18	19	20	21	22	23
Lifting Radius [m]	3.455	3.660	3.865	4.070	4.275	4.480	4.685	4.890	5.095
WLL [kg]	355	330	305	285	265	245	230	215	200
Profile Height [m]	0.425	0.400	0.400	0.400	0.400	0.400	0.400	0.400	0.400
Profile Mass [kg]	7.7	7.3	7.3	7.3	7.3	7.3	7.3	7.3	7.3
Deflection from WLL [m]	0.06	0.06	0.07	0.07	0.07	0.07	0.07	0.07	0.07

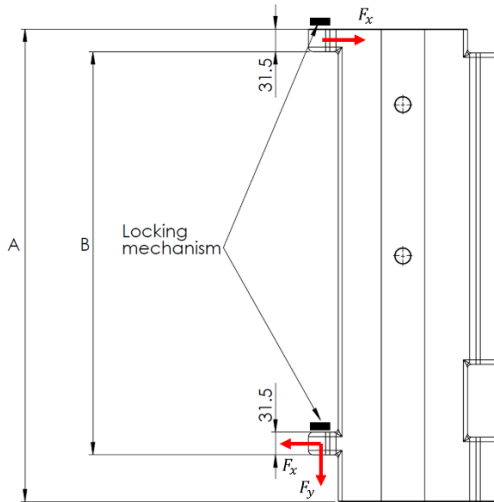

Figure 2: Following structural requirements applies to the supporting structure. The reactions are omnidirectional and characteristic loads that includes dynamic amplification factor (DAF) but without partial coefficients / safety factor.

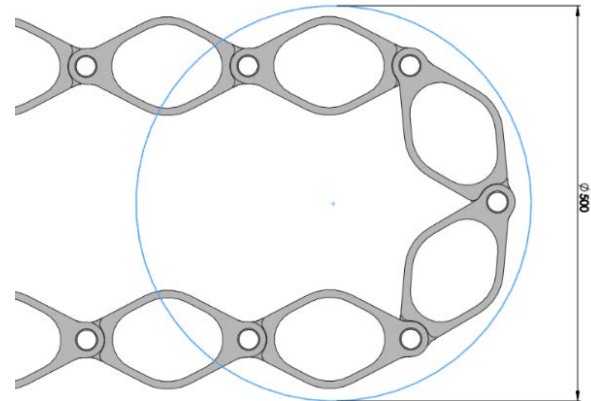

Figure 3: The JibFlex has a bending radius of 250 mm.

Specifications		
Weight of JibFlex <ul style="list-style-type: none"> JibFlex modules Stork Total 	kg	217
	kg	12
	kg	229
WLL at last module	kg	200
Max radius	m	5
Maximum deflection cause by WLL	m	0.07
Safety factor including DAF	-	1.95
Maximum hoist speed	m/s	Unlimited
Installation requirements <ul style="list-style-type: none"> A B Fx Fy 	m	0.775
	m	0.683
	N	27500
	N	8500
Bending Radius	m	0.25

Part List

A complete JibFlex consists of the following:

Main Parts

Part Number	ID	Description	Quantity
1	M-775-1	Module 1	1
2	M-750-1	Module 2	1
3	M-725-1	Module 3	1
4	M-700-1	Module 4	1
5	M-675-1	Module 5	1
6	M-650-1	Module 6	1
7	M-625-1	Module 7	1
8	M-600-1	Module 8	1
9	M-575-1	Module 9	1
10	M-550-1	Module 10	1
11	M-525-1	Module 11	1
12	M-500-1	Module 12	1
13	M-475-1	Module 13	1
14	M-450-1	Module 14	1
15	M-425-1	Module 15	1
16	M-400-1	Module 16-23	8
17	S-006	Stork, six holes*	1

Replacements of any main parts requires new load test.

* The standard stork has six holes.

Spare Parts

Part Number	ID	Description	Quantity
18	S-015	Ø19 Lockpins	2
19	S-013	Ø16 Shackle	1
20	S-014	Linchpin	6
21	PB-001	Bushings with flange	46
22	LB-001-1	LockBrackets Ø44 67,5	23
23	LB-008-1	LockBracket tool	1

Spare parts can be replaced during daily maintenance.

Spare Parts, optional

Part Number	ID	Description	Quantity
	S-008	Stork, eight holes	1
	S-003	Delta Stork	1
	WH-001	Flexhose	1
	WH-002	M6 bolt	23
	WH-003	M6 washer	23
	WH-004	Flexhose Clip	23
	AP-001-1	Standard bracket	2